



INTERNATIONAL APPLICATION PUBLISHED UNDER THE PATENT COOPERATION TREATY (PCT)

<p>(51) International Patent Classification ⁶ : B01D 69/08, 71/34, 61/14, 67/00</p>	<p>A1</p>	<p>(11) International Publication Number: WO 99/01207 (43) International Publication Date: 14 January 1999 (14.01.99)</p>
<p>(21) International Application Number: PCT/CA98/00614 (22) International Filing Date: 29 June 1998 (29.06.98) (30) Priority Data: 08/886,652 1 July 1997 (01.07.97) US (71) Applicant: ZENON ENVIRONMENTAL INC. [CA/CA]; 845 Harrington Court, Burlington, Ontario L7N 3P3 (CA). (72) Inventors: MAHENDRAN, Mailvaganam; 148 Annabelle Street, Hamilton, Ontario I9C 3T9 (CA). GOODBOY, Kenneth, Paul; 2695 Timberglen Drive, Wexford, PA 15090-7562 (US). BAI, Jinhua; 2150 Lilnan Court, No. 6, Burlington, Ontario L7R 1X2 (CA). (74) Agent: ROCK, H., Wayne; MacRae & Co., P.O. Box 806, Station "B", Ottawa, Ontario K1P 5T4 (CA).</p>		<p>(81) Designated States: AU, BR, CA, HU, JP, KR, MX, PL, European patent (AT, BE, CH, CY, DE, DK, ES, FI, FR, GB, GR, IE, IT, LU, MC, NL, PT, SE). Published <i>With international search report.</i></p>

(54) Title: FILTRATION MEMBRANE WITH CALCINED α -ALUMINA PARTICLES THEREIN

(57) Abstract

A filtration membrane for micro- or ultra-filtration is formed from a complex of PVDF and calcined α -alumina (" α -Al") particles, in which complex the particles are reacted and dispersed. The suspended complex is then mixed with a hydrophilic polymer such as polyvinyl alcohol (40 % - 90 % hydrolyzed) referred to herein as HPVA, which reacts with the complex imparting hydrophilicity to the polymer. The novel membrane provides about 50 % higher specific flux than a membrane made with the same polymer but without the α -Al particles. Unexpectedly, the net flux is improved by treating the membrane with a solution of sodium hypochlorite which fails to remove the HPVA from the novel membrane but does remove it from the prior art membrane which does not contain the α -Al. The preferred membrane comprises a macroporous support coated on its outer surface with a thin tubular asymmetric semipermeable film of polymer containing less than about 50 % by weight of α -Al particles.

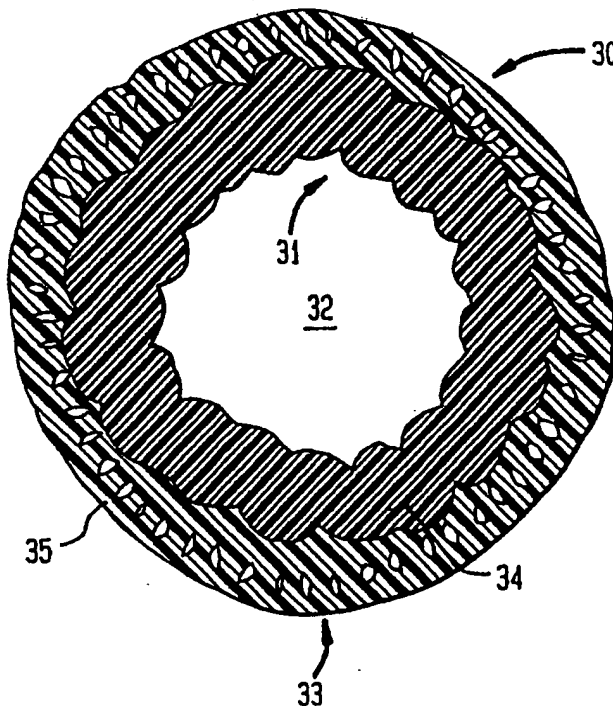

FOR THE PURPOSES OF INFORMATION ONLY

Codes used to identify States party to the PCT on the front pages of pamphlets publishing international applications under the PCT.

AL	Albania	ES	Spain	LS	Lesotho	SI	Slovenia
AM	Armenia	FI	Finland	LT	Lithuania	SK	Slovakia
AT	Austria	FR	France	LU	Luxembourg	SN	Senegal
AU	Australia	GA	Gabon	LV	Latvia	SZ	Swaziland
AZ	Azerbaijan	GB	United Kingdom	MC	Monaco	TD	Chad
BA	Bosnia and Herzegovina	GE	Georgia	MD	Republic of Moldova	TG	Togo
BB	Barbados	GH	Ghana	MG	Madagascar	TJ	Tajikistan
BE	Belgium	GN	Guinea	MK	The former Yugoslav Republic of Macedonia	TM	Turkmenistan
BF	Burkina Faso	GR	Greece	ML	Mali	TR	Turkey
BG	Bulgaria	HU	Hungary	MN	Mongolia	TT	Trinidad and Tobago
BJ	Benin	IE	Ireland	MR	Mauritania	UA	Ukraine
BR	Brazil	IL	Israel	MW	Malawi	UG	Uganda
BY	Belarus	IS	Iceland	MX	Mexico	US	United States of America
CA	Canada	IT	Italy	NE	Niger	UZ	Uzbekistan
CF	Central African Republic	JP	Japan	NL	Netherlands	VN	Viet Nam
CG	Congo	KE	Kenya	NO	Norway	YU	Yugoslavia
CH	Switzerland	KG	Kyrgyzstan	NZ	New Zealand	ZW	Zimbabwe
CI	Côte d'Ivoire	KP	Democratic People's Republic of Korea	PL	Poland		
CM	Cameroon	KR	Republic of Korea	PT	Portugal		
CN	China	KZ	Kazakistan	RO	Romania		
CU	Cuba	LC	Saint Lucia	RU	Russian Federation		
CZ	Czech Republic	LI	Liechtenstein	SD	Sudan		
DE	Germany	LK	Sri Lanka	SE	Sweden		
DK	Denmark	LR	Liberia	SG	Singapore		
EE	Estonia						

**FILTRATION MEMBRANE WITH CALCINED α -ALUMINA
PARTICLES THEREIN**

BACKGROUND OF THE INVENTION

5 This invention relates to a microfiltration (MF) or ultrafiltration (UF) membrane of organic polymer for filtering a desired liquid from a liquid mass referred to herein as a "substrate".

 The membrane may be in the form of a capillary tube or hollow fiber membrane (or "fiber" for brevity), or, in the form of a tubular sheath
10 of film formed either on the inner or outer surface of a tubular macroporous support; or a laminar sheet or film; or a laminar sheet or film deposited on a porous support. In the art, a hollow fiber of microporous polymer, or, a tube of braid having a nominal inside diameter of less than 2.5 mm, coated with a semipermeable film of microporous
15 polymer is referred to as a hollow fiber membrane. A hollow fiber membrane which does not require a support, by definition, is self-supporting. A tubular sheath of thin film of polymer, by itself, or a sheet of thin film, by itself, is non-self-supporting and must be supported. The term "membrane" is used to refer to a film or sheet or the hollow fiber
20 membrane in its entirety, irrespective of the form in which it is deployed. A particular example of a hollow fiber membrane is an extruded hollow fiber membrane with an outer diameter in the range from about .25 mm to 2.5 mm and a wall thickness in the range from about .15 mm to 1 mm, typically being in the range from about 5% to about 40% of the outside
25 diameter of the fiber. The average pore cross sectional diameter in a fiber may vary widely. For MF, the average pore diameter is in the range from about 0.08 μm to about 2.0 μm , preferably from about 0.1 - 1 μm . For UF, the average pore diameter is preferably in the range from about 0.01 μm to 0.1 μm . An example of a supported membrane is a flexible laminar
30 sheet; or a tube of knitted or woven flexible braid coated with the tubular film, the tube having an outside diameter in the range from about 0.5 mm to about 5 mm. For the sake of clarity, reference to the film, by itself, is

made with the term "film membrane", or "thin film" or "film" for brevity, since without the film there would be no membrane. Since the support for a film membrane has macropores which are very large relative to pores within the film, they are referred to herein as "voids".

5 A tubular sheath of non-supporting film has such a thin wall, in the range from 0.01 mm to 0.09 mm thick, the tube will collapse unless supported by fluid. If a thin sheet of film 0.09 mm thick is either extruded or cast, a piece of the film in a small square 10 cm on each side, has so little strength that, by itself, it cannot be manually or mechanically
10 manipulated without being damaged. Yet, its very thin cross-section and non-self-supporting nature, such a film, derived from the synthetic resinous material provides a semipermeable film having excellent semipermeable properties so long as the film is suitably deployed, and, a geometry favored by the film, is maintained. The membrane may be operated as MF or UF
15 under a vacuum drawn on the "lumens" (bores of the fibers) in the range from 1 mm (.02 psi) to about 517 mm (10 psi) of Hg, and under an overall differential in hydrostatic pressure in the range from about atmospheric 101 kPa (14.7 psi) to 300 kPa (43.54 psi), preferably less than 275 kPa (40 psi) for MF flow; and, from about 300 kPa (43.54 psi) to about 690 kPa
20 (100 psi), preferably less than 600 kPa (87 psi) for UF flow.

 The art of forming either self-supporting hollow fibers, or a non-supporting thin film supported on a tubular braid is well known, given the specific polymer which has been found to lend itself to being formed with the physical structure required to function as a semipermeable membrane
25 for filtration of a liquid.

 Though numerous ultrafiltration membranes are available, the search to find a membrane with optimum properties is unremitting. The problem is to find a membrane which allows filtration of the desired liquid with a high flux which is maintained over a long period of operation.
30 Knowing that a polymer can yield a semipermeable membrane having a gradient porosity therethrough, with requisite orientation, is insufficient information for one skilled in the art to make the membrane. For

example, polyvinylidene difluoride (PVDF) in a specified range of molecular weights will yield a filtration membrane, however its long term performance will be poor due to fouling, and, to filter an aqueous substrate with desirable performance, should be made hydrophilic.

5 Polypropylene will yield a filtration membrane only if it is oriented after it is cast in a particular range of thickness, and should be prepped, for example with alcohol, before using the membrane to filter an aqueous substrate. Knowing that polymer when cast or extruded will yield a microfiltration or ultrafiltration membrane, one skilled in the art must still
10 know details relating to how the solution of polymer ("dope") is to be manipulated, if they are to prepare a membrane which is usable for a specified purpose.

The physical solution to the problem lay in finding a particular, highly stable polymer which lent itself to having its structure modified so
15 as to produce a membrane with excellent flux and reliability in operation.

U.S. Patent No. 5,130,342 to McAllister et al discloses particle-filled microporous materials in which substantially non-agglomerated inert filler particles are dispersed in a thermoplastic polymer. There is no evidence provided that a usable filtration membrane can be formed as disclosed,
20 and no evidence that any membrane formed as disclosed was effective as a filter in any liquid substrate.

Japanese JP 58093734 A teaches that a hydrophilic PVDF membrane is produced by treating a membrane of PVDF, or copolymers of PVDF, containing a fine powder of hydrophilic inorganic particles, with
25 an aqueous alkali. Silicic acid, calcium silicate, alumina and magnesium oxide are specified, and it is stated that use of these powders enables the wetting treatment of the membrane to be omitted. There is no suggestion that any specified powder or contents of the powder, which would react with the polymer and calcined α -alumina is not specified. Neutral alumina
30 will not react with PVDF in a solvent in which neutral alumina is inert, and such particles substituted for calcined α -alumina particles are relatively ineffective. It is well known to treat a PVDF membrane (not

PVDF polymer), first with base, then with acid, to improve its hydrophilicity. Preparing the complex, as we have, avoids the post-treatment of the membrane.

SUMMARY OF THE INVENTION

5 It has been discovered that an asymmetric semipermeable membrane may be formed from a polymeric film of polyvinylidene difluoride (PVDF) grafted with a hydrophilic polymer, the film supported on a macroporous support, in which film a minor amount by weight of calcined α -alumina particles (hereafter calcined α -alumina particles are referred to as " α -Al" for brevity), less than 50 percent by weight (% by wt) 10 of the film, preferably less than 20 % by wt, are dispersed. It is critical that the particles be α -Al which are basic (pH in the range from about 8 to about 10) and that they be added prior to grafting the hydrophilic polymer. Addition of more α -Al than specified produces a membrane unusable in 15 filtering a liquid.

More specifically, when PVDF is dissolved in a suspension of α -Al particles, a reaction product (referred to herein as a "PVDF/ α -Al complex") results. When this complex containing less than 50% by weight, based on the combined weight of α -Al and PVDF polymer, is reacted with 20 a hydrophilic polymer in the presence of acid, a dope with appropriate viscosity is obtained; and, when this dope is formed into a semipermeable filtration membrane, the membrane unexpectedly (i) yields much higher flux than is obtained with the blend of PVDF and the hydrophilic component without the particles, and (ii) is resistant to rupture, yet (iii) 25 may be formed with a smooth outer surface which is not easily fouled. Moreover, when a prior art membrane is made with PVDF blended with hydrolyzed polyvinyl acetate (hydrolyzed in the range from 40% - 90%), but without α -Al particles in the membrane, the hydrophilic component may be removed from the membrane by treatment with aqueous sodium 30 hypochlorite (NaOCl), other alkali metal hypochlorite and other oxidizing agents. The hydrophilicity of such a prior art membrane is thus greatly reduced and the flux decreased with time. In contrast, a membrane made

with the complex, treated identically with aqueous NaOCl, retains the hydrolyzed vinyl acetate; and, unexpectedly, its flux is improved. The average diameter of pores of a preferred MF membrane may range from about 0.08 μm to 0.3 μm .

5 More specifically it has been discovered that when the complex is reacted with a polymer having hydrophilic groups which are grafted onto the base polymer, specifically PVDF, to yield a membrane, its flux is higher than that of a membrane made with the same grafted polymer without α -Al particles; and the surface smoothness (or mean roughness
10 "Ra") of the novel membrane is better than that of the same membrane without the particles. The roughness was measured from Atomic Force Microscope (AFM) images of various samples, as set forth below. Smoother membranes are less prone to fouling by particulate matter adhering to it.

15 Further, it has been discovered that hydrophilicity is destroyed in a prior art PVDF/HPVA blend without α -Al particles when the membrane is treated with an aqueous alkali metal hypochlorite solution. In contrast, so long as the novel membrane contains the α -Al particles, the membrane may be treated with the same alkali metal hypochlorite solution and its
20 flux is enhanced (relative to that obtained prior to treatment) without destroying the hydrophilicity of the polymer. Most preferred grafting copolymer is the aforementioned hydrolyzed polyvinyl acetate, referred to in the art as hydrolyzed polyvinyl alcohol (40% - 90% hydrolyzed), and referred to herein as HPVA.

25 The method for making the preferred embodiment of the tubular filtration membrane supported on braid comprises, (a) introducing a flexible tubular braid into a coating nozzle, and into a rounding orifice therein, (b) dispersing α -Al particles in a solution of PVDF and adding a hydrophilic polymer in the presence of acid to yield a grafted polymer in a
30 dope having a viscosity sufficient to provide a coating on a support, (c) extruding the dope on to the support at a rate sufficient to form a continuous layer of dope, (d) maintaining a longitudinal and axial tension

on the braid sufficient to advance it through the nozzle, and (e) coagulating the dope to form a semipermeable film of polymer adherently secured to the tubular braid.

BRIEF DESCRIPTION OF THE DRAWING

5 The foregoing and additional objects and advantages of the invention will best be understood by reference to the following detailed description, accompanied with schematic illustrations of preferred embodiments of the invention, in which illustrations like reference numerals refer to like elements, and in which:

10 Figure 1 illustrates a proposed scheme for reactions which result in formation of a polymer used to make the film of the membrane of this invention.

 Figure 2 is a cross-sectional end view of a hollow fiber membrane formed on a tubular braid, schematically illustrating the radially disposed
15 annular zones which extend longitudinally axially over the length of the membrane, and showing how the tubular non-self-supporting film is supported on the braid, preferably without being embedded therein so as not to impregnate the wall of the braid completely.

 Figure 3 is an illustrative cross-sectional view of the film on the
20 braided tubular membrane, showing greatly enlarged dimensions, to illustrate the dimensional relationships of pores in the component layers of the braid-supported membrane which relationships make the membrane so effective for MF and UF.

 Figure 4 is a photomicrograph of a cross section of PVDF/ α -
25 Al/HPVA MF film, showing a structure corresponding to that illustrated in Fig 3. The components of the film are present in the ratio 15/1/1 respectively (6% α -Al % by wt of the film), the scale corresponding to 50 μ m indicating a relatively low magnification.

 Figure 5 is a photomicrograph taken from directly above the outer
30 circumferential surface of a PVDF/ α -Al/HPVA MF film on a woven braid support, showing the scale corresponding to 5 μ m, indicating a magnification about 7.5X higher than that used in Fig 4.

Figure 6 is an infrared (IR) spectra of a prior art PVDF/HPVA blend containing no calcined (α -Al) particles, before being treated with sodium hypochlorite (NaOCl) solution.

Figure 7 is an infrared (IR) spectra of the same prior art PVDF/HPVA blend of Fig 6, after being treated with NaOCl solution.

Figure 8 is an infrared (IR) spectra of a PVDF/ α -Al/HPVA membrane containing calcined α -alumina (α -Al) particles, before being treated with NaOCl solution.

Figure 9 is an infrared (IR) spectra of the same PVDF/calcined α -Al/Hydrolyzed polyvinyl acetate membrane of Fig 7, after being treated with NaOCl solution.

Figure 10 is a graph showing the net flux of the novel calcined α -Al-containing membrane(11% α -Al by wt) in microfiltration of Lake Ontario water.

Figure 11 is a graph showing the performance of PVDF/ α -Al/HPVA membrane in a direct comparison with a prior art PVDF/HPVA membrane.

DETAILED DESCRIPTION OF PREFERRED EMBODIMENTS

The spatially symmetrical disposition of the hydrogen and fluorine atoms along the PVDF chain gives rise to properties which make PVDF unique among a large number of polymers which can be formed to provide a MF or UF membrane. Since it is well known that the stability of PVDF approaches the essentially inert attribute of fully fluorinated polymers, it is especially noteworthy that the addition of a powder of calcined α -alumina particles to a solution of PVDF in N-methyl-2-pyrrolidone ("NMP") changes the color of the solution from milky to yellowish brown, and then to purple (depending upon the relative concentrations of NMP, PVDF and calcined α -Al), indicating a reaction. Other polymers which may not be as well-suited for making a liquid filtration membrane as PVDF, are halohydrocarbons adapted to be dehydrohalogenated in a manner analogous to that described herein for PVDF.

The details of the reaction are not precisely known, but there is

indirect and direct evidence to show that PVDF is dehydrofluorinated and/or crosslinks in the presence of calcined α -Al. In the second stage the hydrophilic polymer is grafted in situ onto the PVDF. The polymer is referred to as being grafted in situ because the grafting occurs before the membrane is formed. It is believed that the reactions proceed as illustrated in the scheme shown in Fig 1.

It is well known that PVDF loses hydrogen fluoride in the presence of a base (in the case at hand, base is furnished by calcined α -Al), which causes the polymer to become unsaturated (Fig 1, step 1). If enough double bonds form, some are conjugated, evidenced by intense color of the complex. Concurrently the anion may displace or substitute F in an adjacent chain of polymer to crosslink it (step 2). This becomes evident when concentration of base is increased by adding an excess of base, namely calcined α -Al in an amount of 61% by weight, or more, of total solids in the polymer. A dope containing PVDF/ α -Al/HPVA in the ratio 15/25/1 parts by wt, the remaining being NMP, is rubbery and does not form a usable membrane for filtration of a liquid. It is therefore critical to control the amount of α -Al in the complex.

In the second stage of dope making a hydrophilic polymer which contains hydroxyl groups, a strong aqueous acid like sulfuric acid is added. There are two reactions that can take place: (1) addition of water to the double bond to yield a hydroxylated polymer (step 3), or (2) addition of the hydroxyl group of the hydrophilic polymer to the double bond to yield an in situ grafted polymer (step 4). The addition reaction is catalyzed by acid, so it is essential that there be no base left after step 1 and step 2. Acidification of the unsaturated chain formed after step 1 generates a cation to which, in step 4, the hydrolyzed polymer is grafted, and/or in step 3, water reacts to give the hydroxylated polymer. It is therefore critical that the amount of α -Al be controlled. Evidence of such criticality is presented as follows: If the color does not change when the hydrophilic polymer with acid is added, an excess of base is indicated. This confirms that if, after addition of the hydrophilic polymer, the dope is not acidic,

steps 3 and 4 which are critical, will not occur.

The solution to the problem of improving the flux of a prior art PVDF/HPVA membrane lay in finding that the membrane may be modified by addition of calcined α -Al particles prior to adding the HPVA.

The size of the primary particles of calcined α -Al is preferably in the range from about 0.1 μm to 5 μm , preferably less than 2 μm , most preferably from about 0.2 μm to 1 μm . However, knowing that flux through a membrane (and flow of permeate) is maximized when the membrane is made as thin as possible, it is implicit that introducing solid particles in the membrane introduces much concern not only as to how the ability to form a usable membrane will be affected, but also (a) the effect of the particles on resistance of such a membrane to rupture, and (b) the susceptibility of its surface to fouling. Unexpectedly, the addition of the calcined α -Al yields a rugged and reliable, but thin semipermeable film. Such a film may be coated on a macroporous support in a thickness less than 0.2 mm, preferably less than 0.1 mm thick. A hollow fiber membrane, so obtained is effective for water purification, filtration of a fermentation broth, and other MF and UF applications.

To determine the effect of α -Al alone, and the combination of α -Al and HPVA on the flux of the PVDF membranes, the pure water permeability, molecular weight cut-off (MWCO) and pore diameter of three membranes made from three different dopes PVDF/ α -Al, PVDF/HPVA and PVDF/ α -Al/HPVA were determined. The results are set forth in the following Table 1.

TABLE 1

Membrane	Permeability GFD/psi	MWCO, % 200K, PEO	Pore Diameter μm
PVDF/ α -Al	8.6	93.	0.078
PVDF/HPVA	13.0	85.	0.085
PVDF/ α -Al/HPVA	70.0	80.	0.115

The results above provide clear evidence that the combination of

the hydrophilic component (HPVA) and α -Al increases the flux obtained with α -Al alone by 8 times.

For purposes of the description of the best mode of making and using the invention, a tube of braid formed from a yarn of material insoluble in the dope, is most preferred. Other tubular supports with voids may also be used so long as the material from which such supports are formed, provides apt adherent properties for the film. The voids place the outside surface of the film in restricted fluid communication with the inside surface of the braid. Voids which are smaller than about 10 μ m tend to interfere with the flux, and those larger than 100 μ m tend to have the film penetrate the voids and hang too far down over the yarn forming the voids. Voids which are too large also negate the surprising strength of the film membrane. Instead of being woven as a tube, a fabric may be formed into a tube. Whether the fabric is knitted, braided, woven, non-woven or simply perforated, it may be used, since in each case, such a tube provides a foraminous tubular support with the desired voids or macropores. Netting or mesh fabric such as is known in the trade as cubicle netting 22/1000 made by Frankel Associates of New York, N.Y. of 210 denier nylon, warp-knitted by the Raschel knitting process, such as is used in the '982 membrane may be used, provided the voids are not too large, as specified herebelow for MF or UF use. In an analogous manner, a macroporous sheet may be used to support the membrane.

The number average molecular weight of PVDF from which the film membrane is formed is preferably lower than 10^6 (1,000,000), more preferably less than 100,000 so that it may be formed into a thin film less than 0.2 mm thick in cross-section. The concentration of α -Al in the dope is at least 1% by weight of the film and no more than 50% by wt. Preferably the α -Al particles are present in the dope in an amount in the range from 0.25 to 10 parts per 100 parts by weight of the combined weight of PVDF, hydrophilic polymer and particles; and, most preferably, in a dope containing the complex, the components of the dope are present in amounts in the following ranges set forth in Table 2 below, the

remaining parts being a solvent for PVDF, for example, NMP:

TABLE 2

	Component	Amount, parts by wt/100 parts by wt of
	dope	
5	PVDF	10 to 25
	α -Al	0.5 to 5
	Hydrophilic polymer	0.5 to 5

In addition the dope may contain less than 1 part by weight of surfactants and processing aids suitable for use as dispersants and compatibilizers in the non-aqueous solvent used. The surfactant used may be amphoteric, anionic or cationic, so long as the surfactant and/or processing aid dissolves in NMP and is stable at the temperature at which the dope is extruded or cast. Solvents most commonly used for PVDF include NMP, N,N-dimethylacetamide, N, N-diethylacetamide, dimethyl formamide (DMF), diethyl formamide (DEF), tetrahydrofuran (THF), tetramethyl urea and dimethyl sulfoxide (DMSO).

It is necessary to mix the hydrophilic polymer containing acid into the PVDF/ α -Al complex so that a grafted copolymer is formed. As mentioned earlier when PVDF is added to the suspension of α -Al in in NMP, PVDF dissolves and a color change is observed. However if the acid-containing hydrophilic polymer is added to the suspension of α -Al in NMP to form a mixture, and PVDF is then added to this mixture, no color change is observed. Reason for this is that the acid in the hydrophilic polymer neutralizes the base generated by the α -Al and no dehydrofluorination occurs. The membrane made from a dope made with neutralized α -Al is weak and unusable though it has good flux and rejection. The order of addition of the components is therefore critical. Preferred is 40 - 90% hydrolyzed polyvinyl acetate, more preferably from 40% - 70% hydrolyzed. When a dope is made with powdered neutral α -Al or powdered zirconia instead of calcined α -Al, no color change is observed indicating there is no dehydrofluorination. The hydrophilic polymer used is

not narrowly critical so long as it has a hydroxy or other nucleophilic group present, which could react with the intermediate formed to yield a graft polymer. Useful such polymers include, polymers containing carboxylic acid groups (acrylic, methacrylic acid), glycols (polyethylene glycol), sulfonated (polysulfone or polyethersulfone), or lactams (polyvinyl pyrrolidones) functionalities and cellulose acetate and their derivatives. Concentration of hydrophilic component is preferably in the range from 0.5 to 5 parts by weight, per 100 parts of dope.

The tubular braid has a central longitudinal bore and is preferably made from "ends" which are knitted or woven to form the tubular braid having a foraminous circumferential outer surface interrupted by a multiplicity of overlapping yarns contiguously woven into the tubular braid. The bore of the braid has a nominal inside diameter in the range from about 0.25 mm to 2.3 mm. The woven or knit braid has a wall thickness from about 0.06 mm to about 0.7 mm, preferably being in the range from 0.15 - 0.23 mm. The diameter of the filaments of the ends, and the way the ends are knitted or woven with from about 20 to 100 picks/25.4 mm, preferably from 35 - 50 picks/25.4 mm, result in a braid of arbitrary length which is highly flexible and ideally "flaccid". The outside diameter of the braid ranges from about 0.6 mm to 2.5 mm. The voids in the braid are non-uniformly shaped by the braided yarn or "carriers", the voids being small enough to inhibit substantial penetration of a dope from which the film membrane is formed. The upper portion of the tubular braid provides a continuous support for the film, preferably, without the braid being embedded in the film.

Surfactants include Triton, a long chain fatty acid ester of an aminoalcohol; or, Tamol 731, a sodium salt of a polymeric carboxylic acid, available from Rohm & Haas Co.; sulfonated polysulfone, polyhydroxy alcohol hydrophilic additives, and the like. A suitable surface active agent for use in an aqueous liquid is Darvan C, an ammonium salt of a carboxylated liquid polyelectrolyte available from the R.T. Vanderbilt Company.

The dope preferably has a viscosity in the range from about 8,000 cp to about 120,000 cp at 22°C, the viscosity being chosen according to the thickness of the film to be deposited, whether for MF or UF, and the adherent characteristics of the dope and the material from which the ends are spun. For MF, the viscosity is preferably in the range from about 8,000 to about 50,000 cp; and for UF, the viscosity is preferably > 50,000, in the range from about 50,000 to about 120,000 cp.

Details of the method for producing a braided semipermeable hollow fiber membrane are well known to those skilled in the art and are found, for example, in U.S Patent No. 5,472,607 to Mahendran et al.

Referring to Fig 2 there is shown in a diametrical cross-sectional view, much enlarged, of a tubular braid indicated generally by reference numeral 30 comprising a braid of woven yarn 31 having a "lumen" (inner bore) 32. A thin film membrane, indicated generally by reference numeral 33, is self-adherently secured to the circumferential outer surface 34 which is rough and uneven because it is formed by the interwoven yarn which, in the range of thickness used and the number of picks in which it is woven, does not result in an even surface.

Referring to Fig 3 there is schematically illustrated, greatly enlarged relative to Fig 2, the asymmetric thin film membrane 33, which when formed by being coagulated, is itself striated into an overlying ultrathin barrier layer of "skin" 35 and three distinctly identifiable layers of pores, an outer layer 36, an inner layer 38 and an intermediate transport layer 37 between outer layer 36 and inner layer 38, as evident in great detail in the photomicrograph Fig 4. The skin is a very thin, dense layer of polymer formed as the dope contacts the coagulant. By reason of the manner in which the skin and each layer is formed from the same polymer, the layers have, in a radially inward direction from under the skin to the braided yarn 39 which defines the bore 32, progressively larger pores. Each yarn or "end" 39 consists of a multiplicity of filaments 39', and the circumferential surface of the interwoven strands of yarn does not provide a smoothly cylindrical surface. The skin is generally thinner and the pores

for a MF membrane are larger than those of a UF membrane made from the same polymer.

The α -Al particles dispersed in the polymeric film are evident in the photomicrograph of Fig 4 showing primary particles dispersed in the film. The particles are white dots (because they are far more reflective than the polymer). The shaped grey areas represent polymer which defines the voids, seen as dark areas because they are least reflective. Even at relatively low magnification (the entire white bar, within which the black bar bears the numerically defined dimension, represents $50\mu\text{m}$), the relationship of the skin, the inner and outer layers under the skin, and the distribution of the pores is clearly evident. Individual particles in the range from about $1\mu\text{m}$ to $2\mu\text{m}$ are readily visible though much smaller than the large voids in the inner layer 38 of the film. Larger and smaller particles are identified by reference numerals 41 and 42 respectively. The film photographed was made by coating a braid with dope which was quenched in water at 47°C . The membrane yields a permeability of 23 GFD/psi (US gals/square foot/ pounds per square inch). The preferred temperature range for quenching is from 6°C to 90°C , more preferably from 30°C to 50°C .

Referring now to Fig 5 there is shown a higher magnification photomicrograph of the outer surface. The dense skin is so thin it is essentially transparent. Large primary particles 41 (about $2\mu\text{m}$) and smaller particles 42 are seen as white spots spaced-apart by polymer. The dark spots are voids in the film, the voids appearing substantially circular because they are viewed from above. Such spaced-apart relationship of individual primary particles is possible because of the low concentration of particles, preferably no more than 10% by weight of the film. By varying the ratio of the components in the dope and the conditions under which it is coated on a support, a preferred MF membrane may be formed having pores in the narrow size range from about $0.1\mu\text{m}$ to $0.3\mu\text{m}$. A preferred UF membrane may be formed having pores in the narrow size range from about $0.05\mu\text{m}$ to $0.1\mu\text{m}$.

MF membranes made with dope containing PVDF/ α -Al/HPVA wherein PVDF ranges from 13 to 18 parts by wt, α -Al ranges from 1 to 5 parts and HPVA ranges from 1 to 2 parts, the remaining being NMP, have pores with a mean diam. in the range from about 0.1 μ m to about 0.16 μ m; a 200K molecular weight cut-off (MWCO 200K) in the range from about 80% to 95%; and, a permeability in the range from 30 - 80 GFD/psi at 5 psi.

The measured skin thickness (by electron microscopy) for particular films made for the braided membrane, is given below to appreciate its thickness in relation to the pores of the layers. The approximate ranges of sizes of the pores for preferred MF and UF membranes are given below:

TABLE 3

Thickness	MF, μ m	UF, μ m
Skin 35	0.1 - 1.5	1 - 4
Outer layer 36*	0.5 - 1.0	0.5 - 2
Intermediate transport layer 37*	2 - 6	5 - 10
Inner layer 38*	10 - 40	10 - 150

* average pore diameter

The approximate thickness of each layer in a MF and UF braided membrane are given in the following Table 4.

TABLE 4

Thickness, average	MF, μ m	UF, μ m
Skin 35,	0.1 - 1.5	1 - 4
Outer layer 36	5 - 10	20 - 40
Intermediate transport layer 37	30 - 50	40 - 80
Inner layer 38	100 - 1000	100 - 1000

The foregoing illustrative values extend not only to flaccid or flexible supports but also to relatively rigid supports, e.g. braid made of carbon fiber. "Ends" range in nom. dia. from about 0.05 mm to 0.5 mm, preferably 0.165 mm - 0.302 mm.

The unexpected smoothness of the novel membrane is evident in images of the surfaces of various PVDF membranes with an Atomic Force

Microscope. The images in color do not lend themselves to reproduction in black and white print, and are therefore not included herein, but the measurements of roughness are given for the membranes identified in the following Table 5. The same PVDF homopolymer is used for the preparation of each membrane.

TABLE 5

Membrane	Rq (nm)	Ra (nm)	Rmax (nm)
PVDF ¹	7.643	6.134	43.58
PVDF/ α -Al ²	5.017	3.975	28.709
PVDF/HPVA	15.923	12.26	132.11
PVDF/ α -Al/HPVA	10.667	8.469	63.026

¹homopolymer number avg mol. wt 30,000

²ratio of PVDF/ α -Al is 15/2

³ratio of PVDF/ α -Al/HPVA is 15/2/1

Referring to the IR spectra of a PVDF/HPVA membrane before being treated with NaOCl, shown in Fig 6, a large peak attributable to the HPVA at 1722-1735 cm⁻¹ is clearly present.

Referring to the IR spectra shown in Fig 7, of the same PVDF/HPVA membrane used to obtain the spectra of Fig 6, but after the membrane is treated with NaOCl, the peak attributable to the hydrolyzed vinyl acetate at 1722-1735 cm⁻¹ is greatly diminished. It is evident that the hydrolyzed vinyl acetate is highly susceptible to attack by the NaOCl at the concentration of NaOCl (2000 ppm) used.

Referring now to the IR spectra of a PVDF/ α -Al/ hydrolyzed vinyl acetate membrane before being treated with NaOCl, shown in Fig 8, the large peak attributable to the hydrolyzed vinyl acetate at 1735 is again clearly present.

Referring to the IR spectra shown in Fig 9, of the same PVDF/ α -Al/HPVA membrane used to obtain the spectra of Fig 8, but after the membrane is treated with NaOCl, the peak attributable to the hydrolyzed vinyl acetate at 1735 cm⁻¹ is essentially undiminished relative to the peak

at 1735 cm^{-1} in Fig 8. It is evident that the hydrolyzed vinyl acetate is essentially unattacked by the NaOCl, which can only be the result of grafting of hydrolyzed vinyl acetate to PVDF.

Referring to Fig 10 there is shown a plot of Net Flux (GFD) against vacuum before and after backwashing a vertical skein of braided membranes, as a function of time, using PVDF/ α -Al/HPVA (15/2/1) fiber membranes with a total of 150 ft^2 surface, under conditions which provide a net flux of 40 GFD. At the commencement of the test, the fresh membranes produce 40 GFD at a vacuum of about 4 inches of mercury (4" Hg). At intervals indicated, the net flux is maintained at 40 GFD and the vacuum is read just before backwashing. The membranes are then backwashed, and the vacuum read again. It is seen that, except for a sudden drop in net flux on the 3rd day, a progressively greater vacuum is required to maintain the net flux of 40 GFD until the required vacuum stabilizes after about the eleventh day, indicating the membranes are operating at equilibrium. From experience we find that the net flux obtained with the novel membranes operating in relatively clean water is at least 50 percent higher than that obtained with the prior art PVDF/HPVA membranes operating under identical conditions. This improvement in flux is confirmed even in "dirty" water as is indicated in Fig 10.

Referring to Fig 11 there is plotted the comparative performance of a vertical skein of prior art PVDF/HPVA braided membranes (identified as A31) against PVDF/ α -Al/HPVA membranes (identified as A32), each with 500 ft^2 area, operating in Burlington municipal sludge. The specific flux (GFD/psi) is plotted against time indicating also the temperature at which each reading was recorded. The initial clean water specific flux for the A31 membranes is 20 GFD/psi at 25°C; and for the A32 membranes the specific flux is 36.6 GFD/psi. The plot for the A32/CFA membranes indicates a consistently better specific flux (about 50% better) than that for the A31-MF-200-1 membranes at the same temperature.

The following illustrative examples may be readily practiced by one

skilled in the art and are provided to demonstrate how the preferred braided hollow fiber membrane is made, and how it is used in MF and UF applications.

Example 1

5 Making a representative dope having the following essential components (given in parts per hundred parts by weight of dope):

	N-methyl-2-pyrrolidone (NMP)	82 parts
	polyvinylidene fluoride (PVDF)	15 "
	calcined α -alumina particles (" α -Al")	2 "
10	50% hydrolyzed polyvinyl acetate (HPVA)	1 "
	Total	100 "

70 gm of calcined α -Al particles having an average primary particle size of about 0.4 μ m are weighted in a flask to which 2787 gm of NMP is added and thoroughly mixed in a Sonicator[®] for at least 1.5 hr, to ensure that agglomerates of primary particles are broken up so as to form a suspension in which individual primary particles are maintained in spaced apart relationship with each other in the NMP. The suspension is milky white, the white color being contributed by the white calcined α -Al. To this suspension is slowly added 525 gm of PVDF having a number average mol wt of about 30,000 Daltons while stirring at high speed until addition of the PVDF is complete. During the addition of the PVDF the milky white color of the suspension changes first to pink, then to yellowish brown, at the end to grey/brown. Since PVDF dissolved in NMP produces no color change, and the milky white color of the suspension is attributable to the α -Al particles, the changes in color provide evidence of a reaction between the calcined α -Al or a base present in the calcined alumina.

When the grey/brown color of the NMP/PVDF/ α -Al complex in suspension is stable and does not change upon standing for a sustained period in the range from 4 hr to 24 hr, 118 gm of a 30% solution of 50% HPVA containing 1.6 - 1.7% sulfuric acid in NMP is added to form a dope which is stirred overnight. The dope is then degassed either by letting it

stand for 24 hr, or by centrifuging it. The viscosity of the degassed dope is about 14,500 centipoise (cp).

Example 2

Making the hollow fiber membrane of tubular braid - a MF membrane:

5 The dope formed in Example 1 is fed to a nozzle through which a tubular braid of polyester fibers is advanced at about 12.2 meters/min (40 ft/min). The nozzle has a bore with a nominal inner diameter of 1.5 mm. The rate of flow of solution to the nozzle is adjusted so that the solution is flowed upon and around the periphery of the braid at a pressure of 274
10 kPa (25 psig) over a coating distance of 3 mm (0.125 inch). The braid, coated with the solution is then pulled through a sizing die having a diameter of 2.15 mm, then led into a coagulation tank where the polymer solution is coagulated in water to afford a semipermeable membrane about
15 0.1 mm thick, supported on the tubular braid which assumes an essentially circular cross-section. This coated braid was then quenched by immersion in sequential first and second coagulation baths of water, each at 47°C (116°F). The braided membrane has an essentially circular bore having an i.d. of 0.9 mm and an o.d. of 1.85 mm. It is taken up onto the reel of a winder. In tests, it is found that the braided MF membrane provides
20 excellent results.

 After a section of the braided membrane was washed overnight in cold water, its water permeability is determined by measuring its flux which is found to be 6 LMH/kPa (liters per meter² per hr per kPa) or, permeability of 25 GFD/psi measured at 5 psi. After another section of
25 the braided membrane, it is treated with an aqueous solution containing 2000 ppm of sodium hypochlorite (NaOCl). Water permeability of the NaOCl-treated membrane was found to be 12 LMH/kPa measured at 35 kPa (50 GFD/psi measured at 5 psi). In each case, the pore size measurements and molecular weight cut-off measurements provide
30 evidence that the pores in the film are suitable for microfiltration.

 A photograph of a cross-section of the braided MF membrane, made with an electron microscope, shows the film membrane overlying the

braid to be about 0.05 mm thick. The thickness of the skin 35, and each individual layer 36 - 38 will depend upon the conditions under which the film is made. Measurements made in a vertical plane through the circumference, across the wall of the film, provides the following data on pore sizes:

Section	μm
Skin thickness	0.8
Outer layer 36*	0.781
Intermediate layer 37*	1.5
Inner layer 38*	14 - 32

*average pore size

The braided membrane was used to form a MF filtration module having a vertical skein construction described in Serial No. 08/514,119. The water flux measured under 34.45 kPa (5 psi suction pressure) and 25°C is found to be 510 LMH (300 GFD).

Example 3

A dope of PVDF/ α -Al/HPVA in NMP use hereabove, except having a viscosity of 94,500 cps is fed to a nozzle through which a tubular braid having a bore with a nominal i.d. of 0.9 mm and o.d of 1.6 mm is advanced. As before, the flow of dope is adjusted so that the solution is flowed upon and around the periphery of the braid over a coating distance of 3 mm (0.125 inch). The braid, coated with the solution is then pulled through a sizing die having a diameter of 2.15 mm, then led into a coagulation tank where the polymer solution is coagulated in water to afford a thin semipermeable membrane 0.075 mm thick supported on the braid. The braided UF membrane has an essentially circular bore with an i.d. of 0.9 mm and an o.d. of 1.75 mm. It is taken up onto the reel of a winder. This membrane had a mean pore size of 0.076 μm . A portion of this membrane was tested on pure water, had a permeability of 34 LMH/6.89 kPa (20 GFD/psi).

Example 4

Microfiltration of contents of an activated sludge bioreactor:

The pressure on the outer surface of braided membranes in a module constructed as described above is 35 kPa (5 psig). The temperature of the feed is 35°C and the feed contains 35,000 mg/L of suspended solids including live cells predominantly of *Pseudomonas* bacteria in the size range from 1 μm long and 0.5 μm in nominal diameter. The stable flux obtained is in the range from 25-30 LMH.

Having thus provided a general discussion, described the overall process in detail and illustrated the invention with specific examples of the best mode of making the supported membrane, and purifying water with a skein containing the membranes, it will be evident that the invention has provided a surprisingly effective solution despite the teachings of the art. It is therefore to be understood that, no undue restrictions are to be imposed on the scope of this invention by reason of the specific embodiments illustrated and discussed, and, particularly that the invention is not to be restricted to a slavish adherence to the details set forth herein.

CLAIMS

1. An outside-in hollow fiber asymmetric semipermeable membrane comprising,
5 (i) a macroporous foraminous support means having an outer surface; and
(ii) a polymeric film of a reaction product of (a) a complex of polyvinylidene difluoride (PVDF) with calcined α -alumina particles, and (b) a hydrophilic polymer adapted to impart hydrophilicity to said membrane; said particles having a primary particle size in the range from about 0.1
10 μm to 5 μm being present in an amount at least 1 percent by weight, but less than 50 percent by weight, of said film; said film being supported by said outer surface, and said film having a peripheral barrier layer or "skin" integral with successive microporous layers having pores having an average diameter in the range from about
15 0.01 μm to about 0.3 μm , in open communication with each other.
2. The semipermeable membrane of claim 1 wherein said support means is a tubular support means.
3. The semipermeable membrane of claim 1 wherein said support means is a laminar support means.
- 20 4. The semipermeable membrane of claim 2 wherein said tubular support means is flexible.
5. The semipermeable membrane of claim 2 wherein said laminar support means is flexible.
- 25 6. The semipermeable membrane of claim 4 wherein said membrane is a microfiltration membrane for filtration of liquid, and said tubular support means has an outside diameter in the range from about 0.6 mm to

2.5 mm; and an inside diameter in the range from about 0.25 mm to 2.3 mm.

7. The semipermeable membrane of claim 1 wherein said membrane is formed from a dope of said reaction product which is essentially
5 insoluble in water, said primary particles have an average particle diameter of less than 2 μm , and said membrane has an initial room temperature flux of at least 10 LMH measured with deionized water at a pressure of 200 kPa and 20°C.

8. The semipermeable membrane of claim 7 wherein said film is
10 formed from a dope having a viscosity in the range from about 8,000 cp to about 120,000 cp at 22°C, said film is less than 0.2 mm thick, and has pores in the size range from about 0.1 μm to about 0.3 μm .

9. The semipermeable membrane of claim 2 wherein said tubular
15 support means is a braid, knitted or woven from ends having a diameter in the range from about in the range from about 0.05 mm to 0.5 mm, and said braid has from 5 to 50 picks/25.4 mm.

10. A method for producing a membrane having a semipermeable
20 asymmetric film supported on a flexible support having inner and outer surfaces, and intercommunicating macropores which place said inner and outer surfaces in fluid communication, said method comprising, coating said support's outer surface with a dope of a polymeric reaction product of (i) a complex of polyvinylidene difluoride (PVDF) with calcined
25 α -alumina particles having a primary particle size in the range from about 0.1 μm to about 5 μm , and (ii) a hydrophilic polymer having reactive nucleophilic groups adapted to impart hydrophilicity to said membrane; wherein said complex is formed by dispersing less than 50 parts by weight of said particles per 100 parts by weight of said particles and PVDF in a

solvent for said PVDF;
wherein said reaction product is formed by the addition of said hydrophilic
polymer to said complex in said solvent;
said dope having a viscosity sufficient to be supported on said outer
5 surface, so as to provide said support with a dope-coated surface;
passing said dope-coated surface through a sizing means to provide a wall
thickness of dope on said support sufficient to form a film less than 0.2
mm thick; and,
coagulating said dope.

10 11. The method of claim 10 wherein, for 100 parts by weight of dope,
PVDF is present in an amount in the range from 10 to 25 parts, α -Al
particles are present in an amount in the range from 0.5 to 10 parts, and
hydrophilic polymer is present in an amount in the range from 0.5 to 5
parts, the remaining being solvent.

15 12. The method of claim 11 comprising coating said outer surface with
said dope having a viscosity in the range from 8,000 cp to about 120,000 cp
at 22°C, and said flexible support is a tube.

20 13. A suspension of a complex of calcined α -alumina particles and
polyvinylidene difluoride (PVDF) in a solvent for said PVDF, said complex
being formed by dispersing at least 1 part by weight, but less than 50 parts
by weight of said particles per 100 parts by weight of said particles and
PVDF, in a solvent for said PVDF, said particles having a primary particle
size in the range from about 0.1 μ m to about 5 μ m.

25 14. A method for making a dope to be used to make a filtration
membrane, said method comprising,
preparing a complex consisting essentially of calcined α -alumina particles
in a solvent for polyvinylidene difluoride (PVDF), said complex being
formed by dispersing less than 50 parts by weight of said particles per 100

parts by weight of said particles and PVDF, in a solvent for said PVDF, said particles having a primary particle size in the range from about 0.1 μm to 5 μm ;

5 adding a hydrophilic polymer in a minor amount by weight relative to said PVDF said hydrophilic polymer having reactive nucleophilic groups adapted to react with said complex and impart hydrophilicity to a film formed from said dope;

10 said dope having a viscosity sufficient to provide a continuous coating on a support, said particles being present in said dope in an amount at least 1 percent by weight of the combined weight of said PVDF, said hydrophilic polymer and said particles.

15 15. The method of claim 14 wherein said dope has a viscosity in the range from about 8,000 cp to about 50,000 cp at 22°C for a microfiltration membrane and said particles are present in an amount less than 15 percent by weight of said combined weight.

16. The method of claim 14 wherein said dope has a viscosity in the range from about 50,000 cp to about 120,000 cp at 22°C for an ultrafiltration membrane and said particles are present in an amount less than 20 percent by weight of said combined weight.

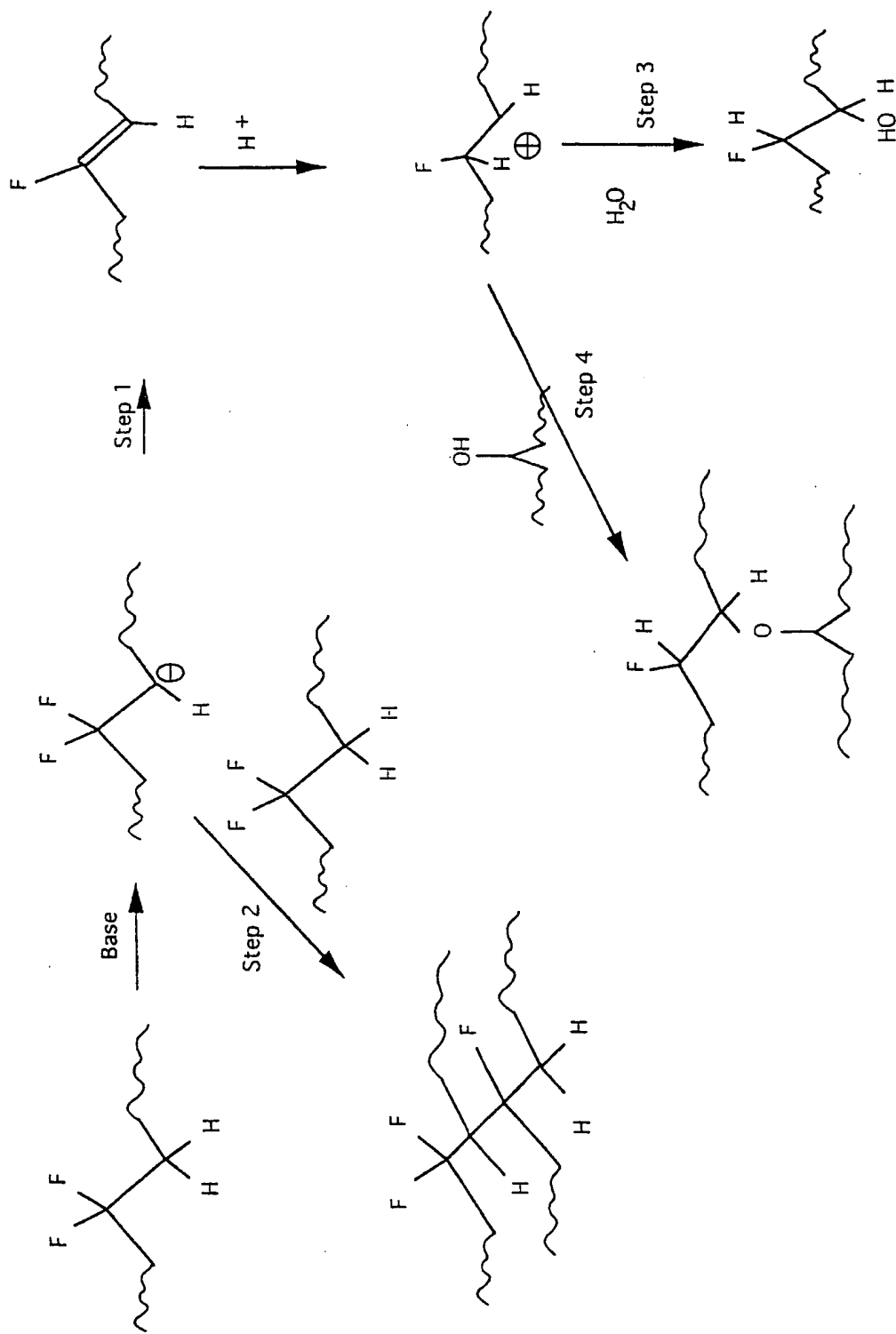

Figure 1

FIG. 2

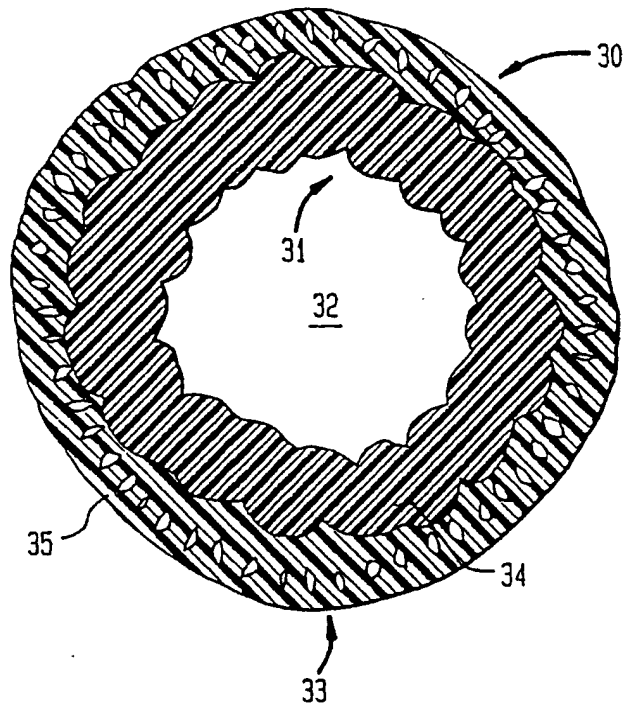
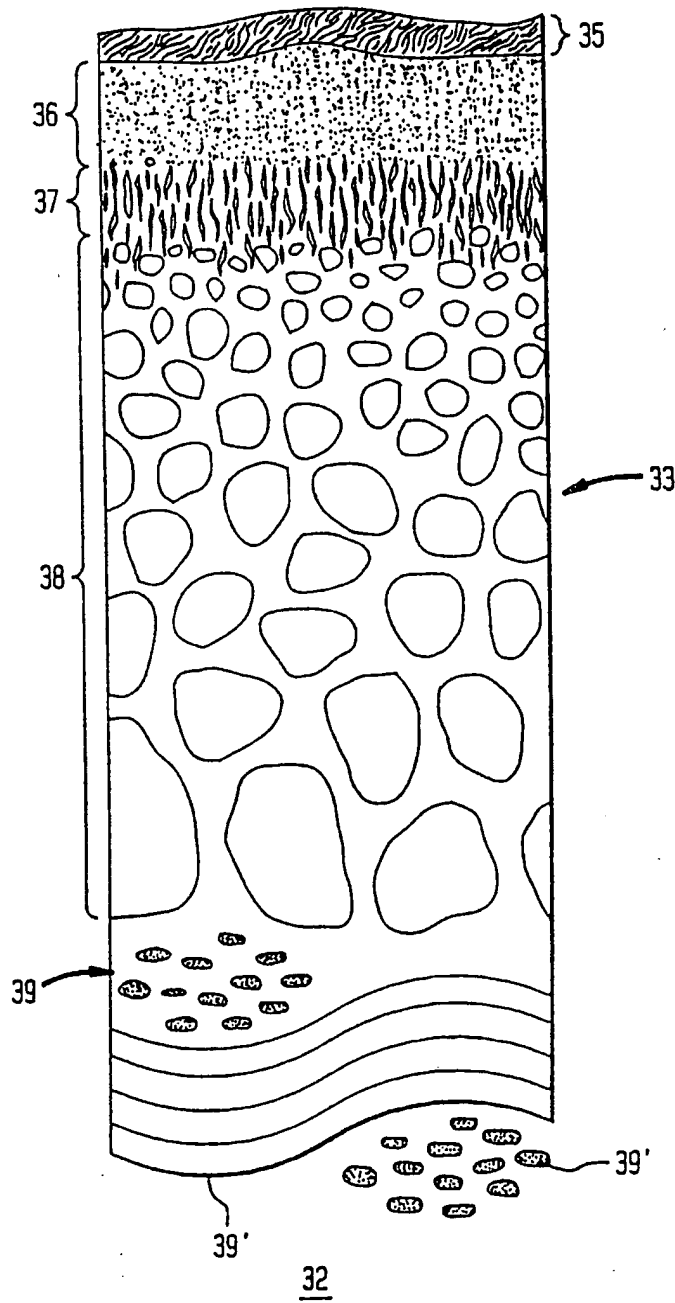

FIG. 3



SUBSTITUTE SHEET (RULE 26)



FIG. 4

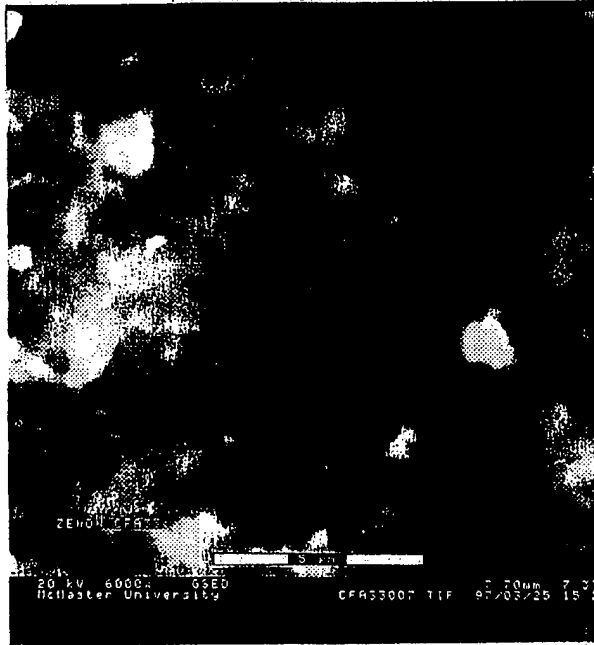

FIG. 5

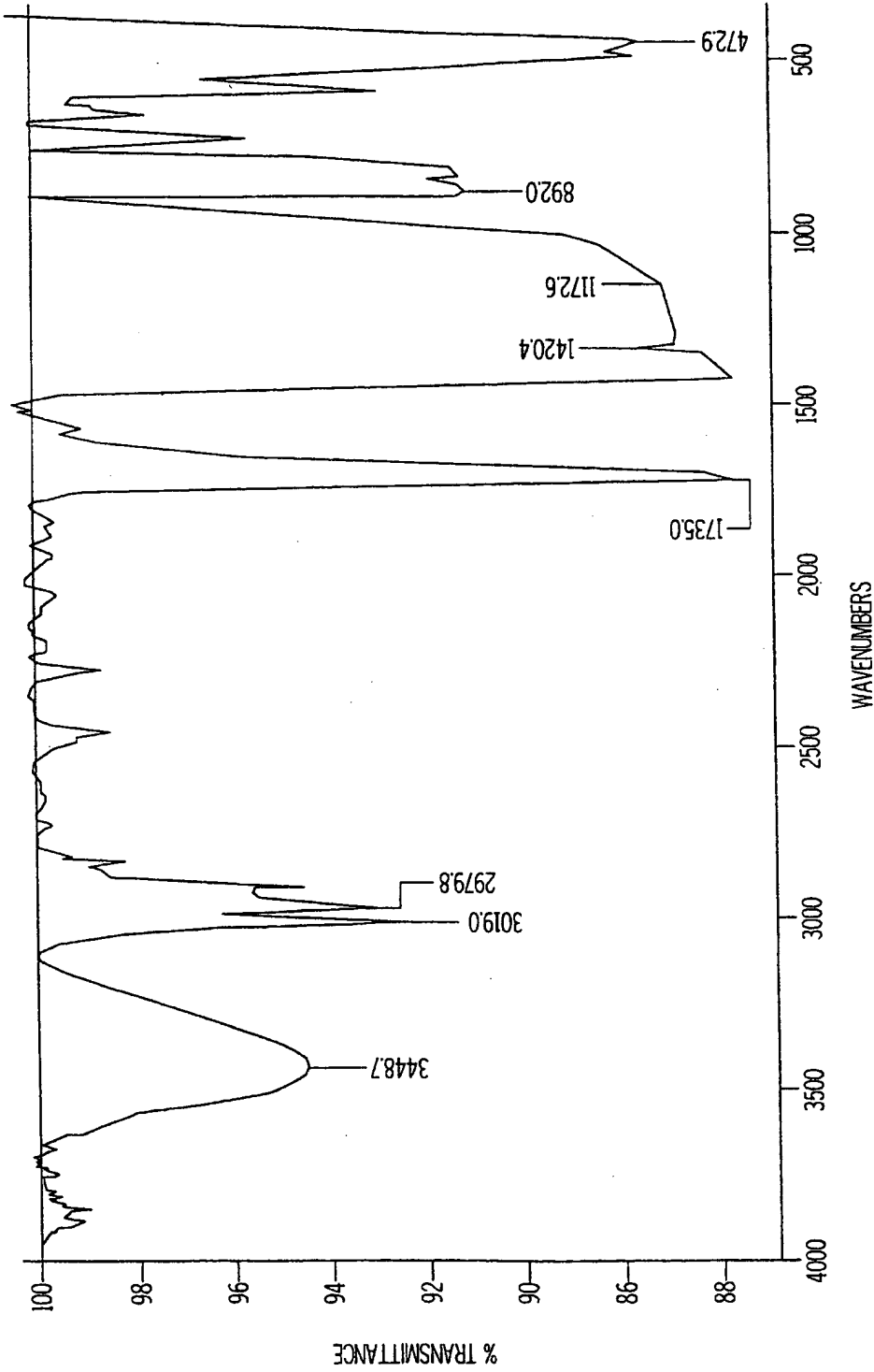

FIG. 6

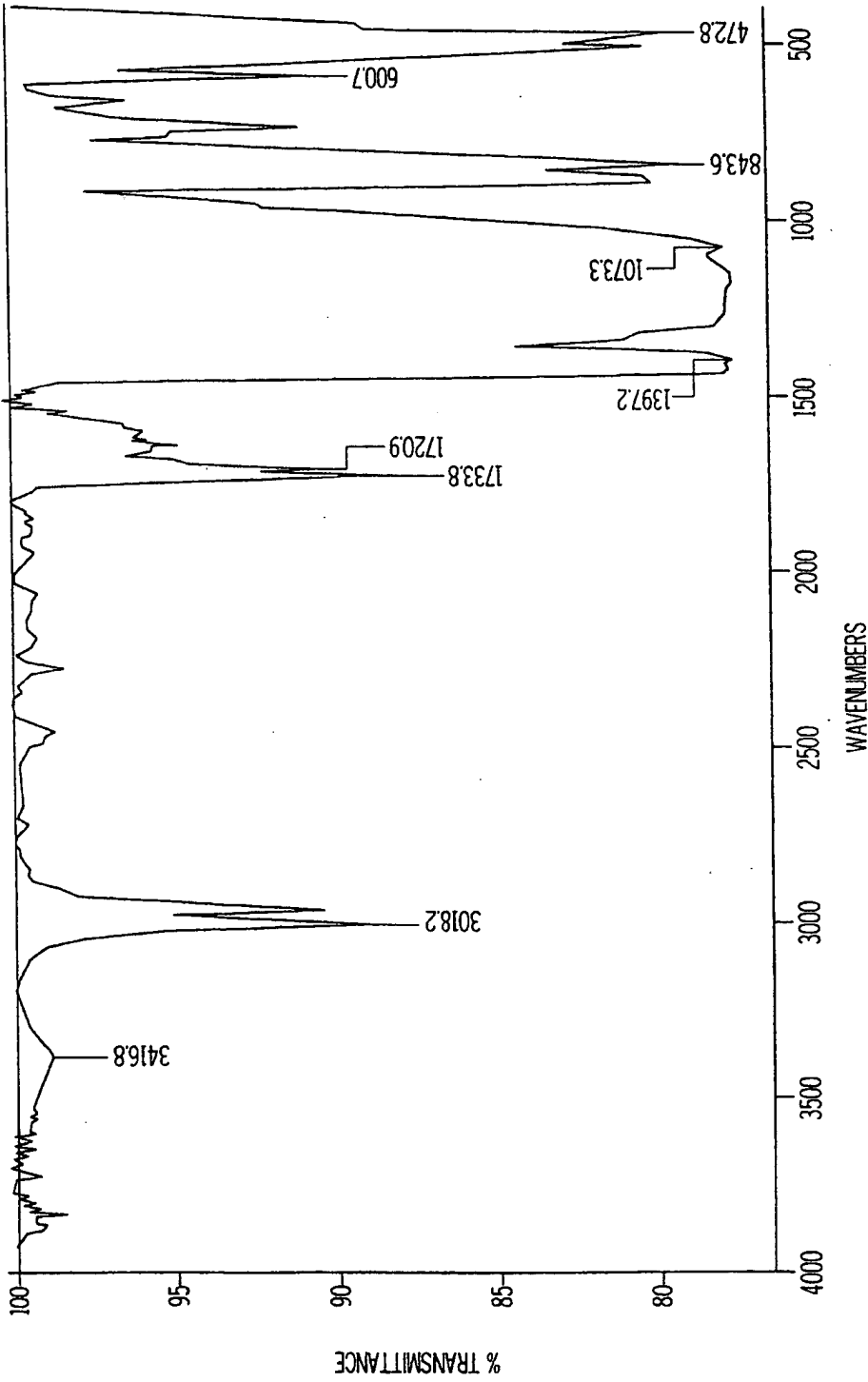

FIG. 7

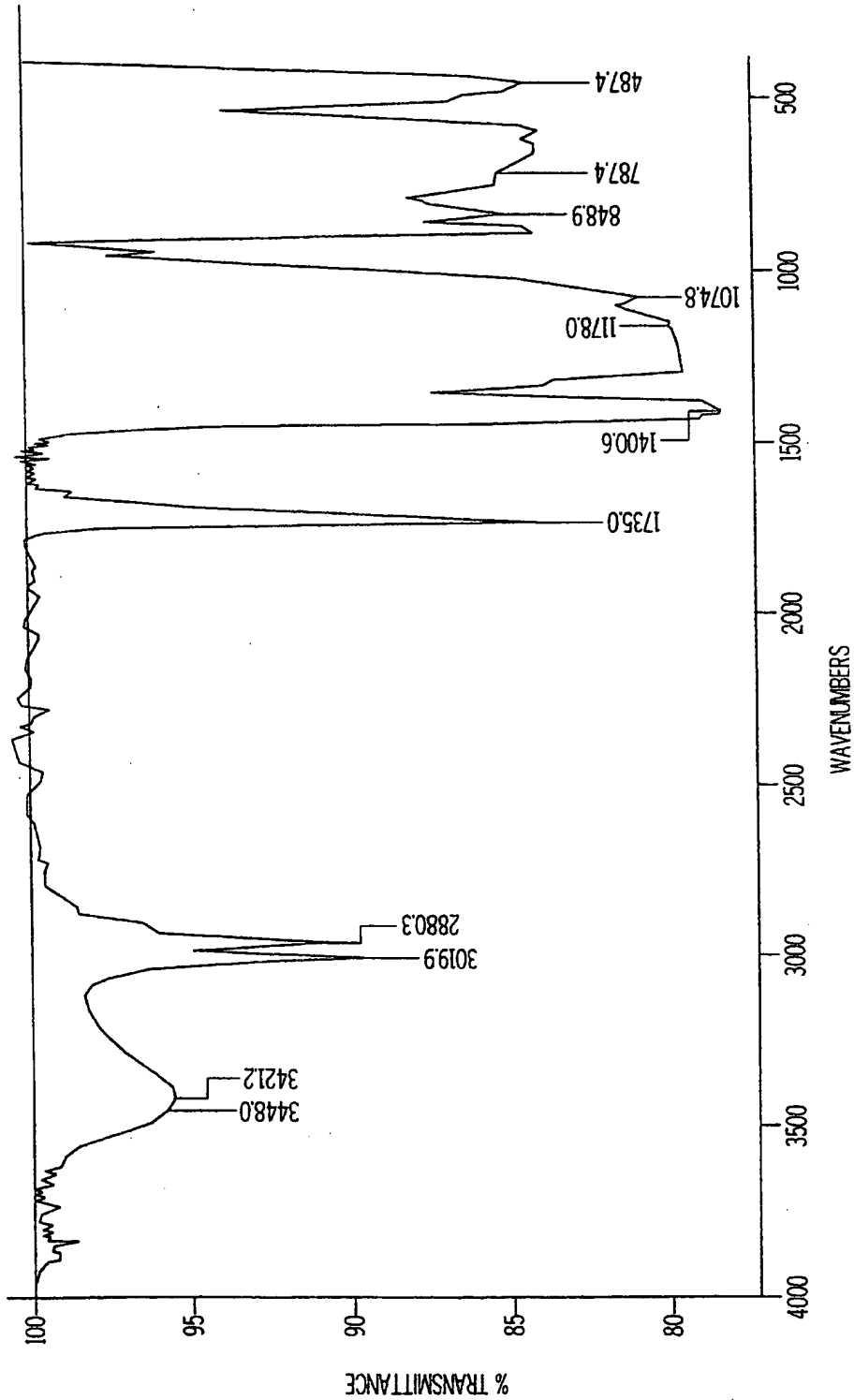

FIG. 8

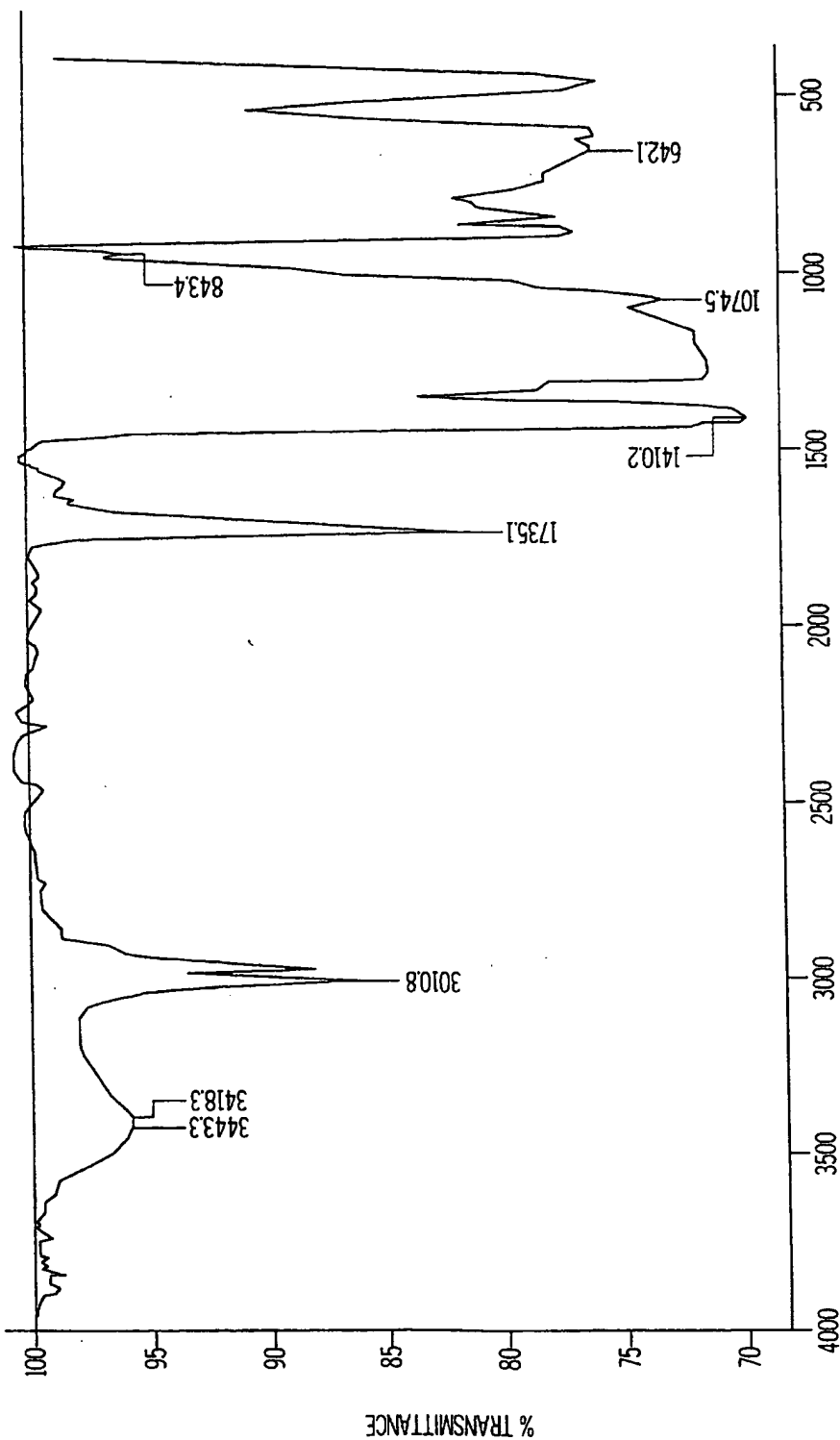

FIG. 9

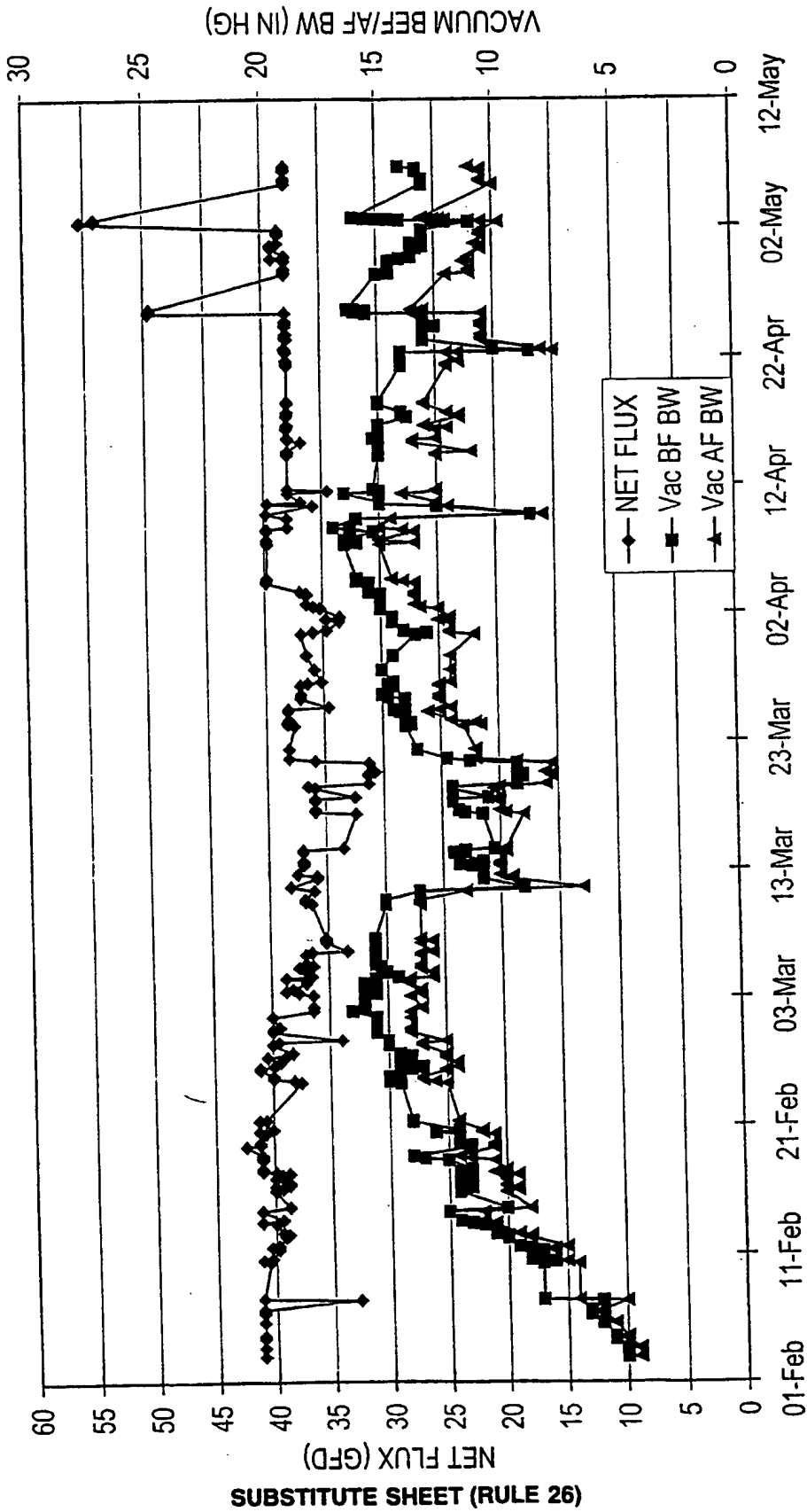

FIG. 10

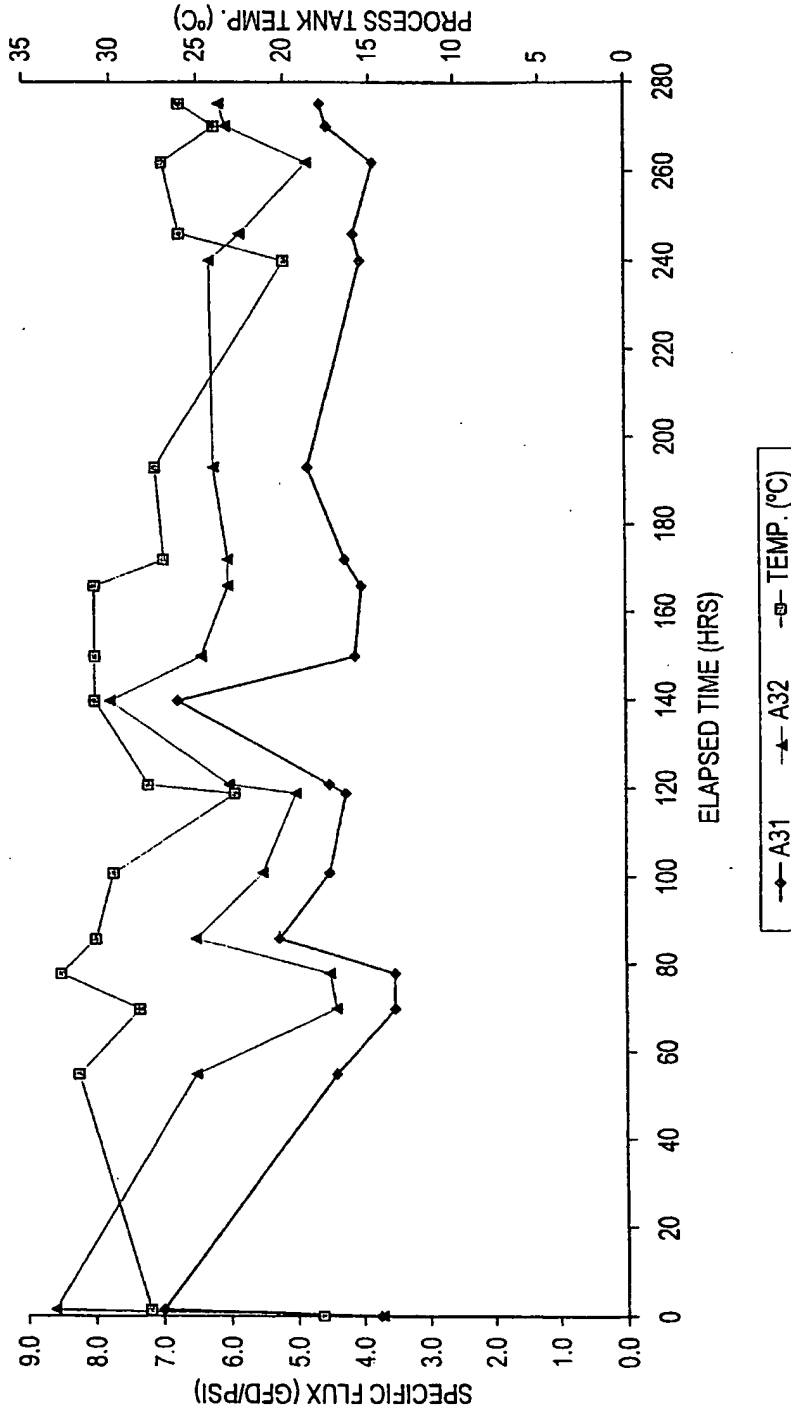

FIG. 11

INTERNATIONAL SEARCH REPORT

International Application No

PCT/CA 98/00614

A. CLASSIFICATION OF SUBJECT MATTER

IPC 6 B01D69/08 B01D71/34 B01D61/14 B01D67/00

According to International Patent Classification (IPC) or to both national classification and IPC

B. FIELDS SEARCHED

Minimum documentation searched (classification system followed by classification symbols)

IPC 6 B01D

Documentation searched other than minimum documentation to the extent that such documents are included in the fields searched

Electronic data base consulted during the international search (name of data base and, where practical, search terms used)

C. DOCUMENTS CONSIDERED TO BE RELEVANT

Category *	Citation of document, with indication, where appropriate, of the relevant passages	Relevant to claim No.
A	US 5 130 342 A (MCALLISTER JEROME W ET AL) 14 July 1992 cited in the application see column 4, line 11 - column 6, line 3 see column 6, line 55 - column 7, line 68 see column 11, line 59 - line 60; example 5	1-16
A	PATENT ABSTRACTS OF JAPAN vol. 007, no. 191 (C-182), 20 August 1983 & JP 58 093734 A (ASAHI KASEI KOGYO KK), 3 June 1983 cited in the application see abstract	1-16
	-/--	

Further documents are listed in the continuation of box C.

Patent family members are listed in annex.

* Special categories of cited documents :

- "A" document defining the general state of the art which is not considered to be of particular relevance
- "E" earlier document but published on or after the international filing date
- "L" document which may throw doubts on priority claim(s) or which is cited to establish the publication date of another citation or other special reason (as specified)
- "O" document referring to an oral disclosure, use, exhibition or other means
- "P" document published prior to the international filing date but later than the priority date claimed

- "T" later document published after the international filing date or priority date and not in conflict with the application but cited to understand the principle or theory underlying the invention
- "X" document of particular relevance; the claimed invention cannot be considered novel or cannot be considered to involve an inventive step when the document is taken alone
- "Y" document of particular relevance; the claimed invention cannot be considered to involve an inventive step when the document is combined with one or more other such documents, such combination being obvious to a person skilled in the art.
- "&" document member of the same patent family

Date of the actual completion of the international search

15 October 1998

Date of mailing of the international search report

22/10/1998

Name and mailing address of the ISA

European Patent Office, P.B. 5818 Patentlaan 2
 NL - 2280 HV Rijswijk
 Tel. (+31-70) 340-2040, Tx. 31 651 epo nl,
 Fax: (+31-70) 340-3016

Authorized officer

Edmueller, P

INTERNATIONAL SEARCH REPORT

International Application No
PCT/CA 98/00614

C.(Continuation) DOCUMENTS CONSIDERED TO BE RELEVANT

Category	Citation of document, with indication, where appropriate, of the relevant passages	Relevant to claim No.
A	WO 95 17242 A (ZENON ENVIRONMENTAL INC) 29 June 1995 cited in the application see claims 1-16; figures 1,2,4; examples 1,2 ---	1-16
A	EP 0 245 000 A (PALL CORP) 11 November 1987 see page 5, line 15 - line 33; claims 1,2 ---	1-16
A	EP 0 012 557 A (ABCOR INC) 25 June 1980 see page 3, line 14 - line 29; examples 1-6 -----	1-16

INTERNATIONAL SEARCH REPORT

Information on patent family members

International Application No

PCT/CA 98/00614

Patent document cited in search report	Publication date	Patent family member(s)	Publication date
US 5130342 A	14-07-1992	US 4957943 A	18-09-1990
		AU 622455 B	09-04-1992
		AU 3669789 A	26-04-1990
		CA 1314668 A	23-03-1993
		DE 68914773 D	26-05-1994
		DE 68914773 T	20-10-1994
		DK 307889 A	15-04-1990
		EP 0365111 A	25-04-1990
		ES 2055060 T	16-08-1994
		HK 167196 A	13-09-1996
		JP 2129239 A	17-05-1990
		MX 166244 B	24-12-1992
		WO 9517242 A	29-06-1995
AU 690948 B	07-05-1998		
AU 1269695 A	10-07-1995		
CA 2178639 A	29-06-1995		
EP 0735917 A	09-10-1996		
EP 0245000 A	11-11-1987	US 4774132 A	27-09-1988
		AU 596840 B	17-05-1990
		AU 7188087 A	05-11-1987
		BR 8702172 A	17-02-1988
		CA 1302177 A	02-06-1992
		DE 3774323 A	12-12-1991
		FI 871934 A	02-11-1987
		GB 2190039 A, B	11-11-1987
		JP 2502309 B	29-05-1996
		JP 62267340 A	20-11-1987
		US 4855163 A	08-08-1989
EP 0012557 A	25-06-1980	US 4248913 A	03-02-1981
		AT 2480 T	15-03-1983
		CA 1132312 A	28-09-1982
		US 4302334 A	24-11-1981
		JP 55102635 A	06-08-1980